



OPERATOR'S AND PARTS MANUAL

PALLET FORKS



PALADIN
LIGHT CONSTRUCTION GROUP



The Power of Combined Excellence

FOR COMPACT TRACTORS



SERIAL NUMBER: _____

MODEL NUMBER: _____

Manual Number: OM722
Part Number: 75622

PREFACE

GENERAL COMMENTS

Congratulations on the purchase of your new BRADCO product! This product was carefully designed and manufactured to give you many years of dependable service. Only minor maintenance (such as cleaning and lubricating) is required to keep it in top working condition. Be sure to observe all maintenance procedures and safety precautions in this manual and on any safety decals located on the product and on any equipment on which the attachment is mounted.

This manual has been designed to help you do a better, safer job. Read this manual carefully and become familiar with its contents.

WARNING!  Never let anyone operate this unit without reading the "Safety Precautions" and "Operating Instructions" sections of this manual. Always choose hard, level ground to park the vehicle on and set the brake so the unit cannot roll.

Unless noted otherwise, right and left sides are determined from the operator's control position when facing the attachment.

NOTE: The illustrations and data used in this manual were current (according to the information available to us) at the time of printing, however, we reserve the right to redesign and change the attachment as may be necessary without notification.

BEFORE OPERATION

The primary responsibility for safety with this equipment falls to the operator. Make sure the equipment is operated only by trained individuals that have read and understand this manual. If there is any portion of this manual or function you do not understand, contact your local authorized dealer or the manufacturer.

SAFETY ALERT SYMBOL



This is the "Safety Alert Symbol" used by this industry. This symbol is used to warn of possible injury. Be sure to read all warnings carefully. They are included for your safety and for the safety of others working with you.

SERVICE

When servicing your product, remember to use only manufacturer replacement parts. Substitute parts may not meet the standards required for safe, dependable operation.

To facilitate parts ordering, record the model and serial number of your unit in the space provided on the cover of this manual. This information may be obtained from the identification plate located on the product.

The parts department needs this information to insure that you receive the correct parts for your specific model.

SAFETY STATEMENTS



THIS SYMBOL BY ITSELF OR WITH A WARNING WORD THROUGHOUT THIS MANUAL IS USED TO CALL YOUR ATTENTION TO INSTRUCTIONS INVOLVING YOUR PERSONAL SAFETY OR THE SAFETY OF OTHERS. FAILURE TO FOLLOW THESE INSTRUCTIONS CAN RESULT IN INJURY OR DEATH.



DANGER

THIS SIGNAL WORD IS USED WHERE SERIOUS INJURY OR DEATH WILL RESULT IF THE INSTRUCTIONS ARE NOT FOLLOWED PROPERLY.



WARNING

THIS SIGNAL WORD IS USED WHERE SERIOUS INJURY OR DEATH COULD RESULT IF THE INSTRUCTIONS ARE NOT FOLLOWED PROPERLY.



CAUTION

THIS SIGNAL WORD IS USED WHERE MINOR INJURY COULD RESULT IF THE INSTRUCTIONS ARE NOT FOLLOWED PROPERLY.

NOTICE

NOTICE INDICATES A PROPERTY DAMAGE MESSAGE.

GENERAL SAFETY PRECAUTIONS

WARNING!

READ MANUAL PRIOR TO INSTALLATION



Improper installation, operation, or maintenance of this equipment could result in serious injury or death. Operators and maintenance personnel should read this manual, as well as all manuals related to this equipment and the prime mover thoroughly before beginning installation, operation, or maintenance. **FOLLOW ALL SAFETY INSTRUCTIONS IN THIS MANUAL AND THE PRIME MOVER'S MANUAL(S).**



READ AND UNDERSTAND ALL SAFETY STATEMENTS

Read all safety decals and safety statements in all manuals prior to operating or working on this equipment. Know and obey all OSHA regulations, local laws, and other professional guidelines for your operation. Know and follow good work practices when assembling, maintaining, repairing, mounting, removing, or operating this equipment.



KNOW YOUR EQUIPMENT

Know your equipment's capabilities, dimensions, and operations before operating. Visually inspect your equipment before you start, and never operate equipment that is not in proper working order with all safety devices intact. Check all hardware to ensure it is tight. Make certain that all locking pins, latches, and connection devices are properly installed and secured. Remove and replace any damaged, fatigued, or excessively worn parts. Make certain all safety decals are in place and are legible. Keep decals clean, and replace them if they become worn or hard to read.

GENERAL SAFETY PRECAUTIONS

WARNING!



PROTECT AGAINST FLYING DEBRIS

Always wear proper safety glasses, goggles, or a face shield when driving pins in or out, or when any operation causes dust, flying debris, or any other hazardous material.

WARNING!



LOWER OR SUPPORT RAISED EQUIPMENT

Do not work under raised booms without supporting them. Do not use support material made of concrete blocks, logs, buckets, barrels, or any other material that could suddenly collapse or shift positions. Make sure support material is solid, not decayed, warped, twisted, or tapered. Lower booms to ground level or on blocks. Lower booms and attachments to the ground before leaving the cab or operator's station.

WARNING!



USE CARE WITH HYDRAULIC FLUID PRESSURE

Hydraulic fluid under pressure can penetrate the skin and cause serious injury or death. Hydraulic leaks under pressure may not be visible. Before connecting or disconnecting hydraulic hoses, read your prime mover's operator's manual for detailed instructions on connecting and disconnecting hydraulic hoses or fittings.

- Keep unprotected body parts, such as face, eyes, and arms as far away as possible from a suspected leak. Flesh injected with hydraulic fluid may develop gangrene or other permanent disabilities.
- If injured by injected fluid, see a doctor at once. If your doctor is not familiar with this type of injury, ask him to research it immediately to determine proper treatment.
- Wear safety glasses, protective clothing, and use a piece of cardboard or wood when searching for hydraulic leaks. **DO NOT USE YOUR HANDS!** **SEE ILLUSTRATION.**

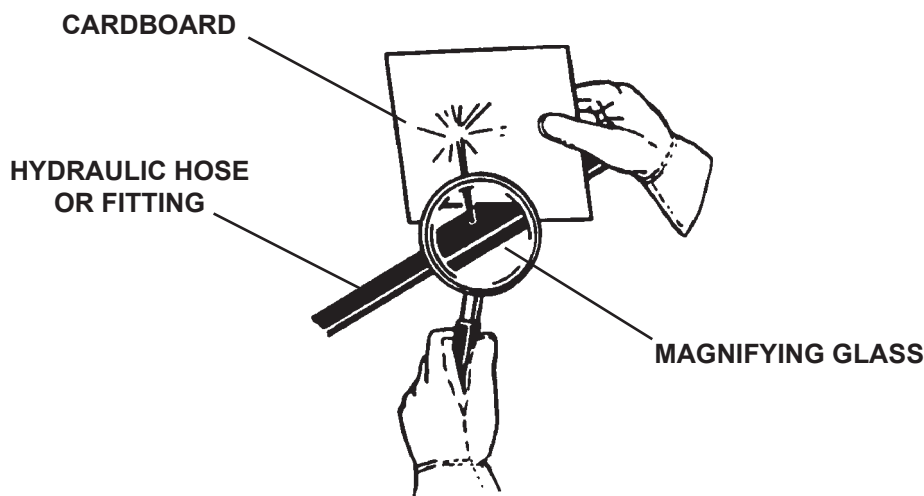

GENERAL SAFETY PRECAUTIONS

WARNING!



DO NOT MODIFY MACHINE OR ATTACHMENTS

Modifications may weaken the integrity of the attachment and may impair the function, safety, life, and performance of the attachment. When making repairs, use only the manufacturer's genuine parts, following authorized instructions. Other parts may be substandard in fit and quality. Never modify any ROPS (Roll Over Protection Structure) or FOPS (Falling Object Protective Structure) equipment or device. Any modifications must be authorized in writing by the manufacturer.

WARNING!



SAFELY MAINTAIN AND REPAIR EQUIPMENT

- Do not wear loose clothing or any accessories that can catch in moving parts. If you have long hair, cover or secure it so that it does not become entangled in the equipment.
- Work on a level surface in a well-lit area.
- Use properly grounded electrical outlets and tools.
- Use the correct tools for the job at hand. Make sure they are in good condition for the task required.
- Wear the protective equipment specified by the tool manufacturer.



SAFELY OPERATE EQUIPMENT

Do not operate equipment until you are completely trained by a qualified operator in how to use the controls, know its capabilities, dimensions, and all safety requirements. See your machine's manual for these instructions.

- Keep all step plates, grab bars, pedals, and controls free of dirt, grease, debris, and oil.
- Never allow anyone to be around the equipment when it is operating.
- Do not allow riders on the attachment or the prime mover.
- Do not operate the equipment from anywhere other than the correct operator's position.
- Never leave equipment unattended with the engine running, or with this attachment in a raised position.
- Do not alter or remove any safety feature from the prime mover or this attachment.
- Know your work site safety rules as well as traffic rules and flow. When in doubt on any safety issue, contact your supervisor or safety coordinator for an explanation.

EQUIPMENT SAFETY PRECAUTIONS

WARNING!



KNOW WHERE UTILITIES ARE

Observe overhead electrical and other utility lines. Be sure equipment will clear them. When digging, call your local utilities for location of buried utility lines, gas, water, and sewer, as well as any other hazard you may encounter.



OPERATING THE PALLET FORK

- Do not mount this attachment onto any prime mover that exceeds 40 HP, 4000 pounds operating weight OR 2300 pounds lifting capacity.
- Specified lift capacities must not be exceeded, otherwise machine stability will not be sufficient. Always observe lift capacity limits listed in machine specifications.
- When operating on a slope, keep the load low, and proceed with caution.
- Do not drive ACROSS a steep slope - drive straight up and down.
 - With LOADED forks - drive with the forks and load facing uphill.
 - With EMPTY forks - drive with the forks facing downhill.
- Never use the attachment for a work platform or personnel carrier.
- An operator must not use drugs or alcohol, which can change his or her alertness or coordination. An operator taking prescription or over-the-counter drugs should seek medical advice on whether or not he or she can safely operate equipment.
- Always check locking pins before operating any attachment.
- Never lift, move, or swing loaded forks over anyone.
- Always space the forks correctly for the load. Loads can fall off incorrectly spaced forks. Make sure the forks are completely under the load before lifting.
- Never stack loads on uneven ground. Loads stacked on uneven ground can topple.
- Never lift a load with one fork. A load lifted with one fork can slip off and cause injury.
- Secure loads properly. Unsecured loads can fall unexpectedly.
- Do not handle round bales with fork lift tines.
- Don't obstruct your vision when traveling or working. Carry the forks low for maximum stability and visibility.



TRANSPORTING THE PALLET FORK

- Travel only with the attachment in a safe transport position to prevent uncontrolled movement. Drive slowly over rough ground and on slopes.
- When driving on public roads use safety lights, reflectors, Slow Moving Vehicle signs etc., to prevent accidents. Check local government regulation that may affect you.
- Do not drive close to ditches, excavations, etc., cave in could result.
- Do not smoke when refueling the prime mover. Allow room in the gas tank for expansion. Wipe up any spilled fuel. Secure cap tightly when done.



MAINTAINING THE PALLET FORK

- Worn, damaged, or illegible safety decals must be replaced. New safety decals can be ordered from the manufacturer.
- Never work under a raised attachment.

INSTALLATION AND OPERATION

GENERAL INFORMATION

The BRADCO Pallet Forks for compact tractors were designed to be used on prime movers up to 40 horsepower with a maximum of 4000 pounds operating weight and 2300 pounds lifting capacity. Operating this attachment on a prime mover that exceeds any of these specifications will cause damage to the attachment and void all warranties.

INSTALLATION

Install the pallet fork by following your tractor and loader operator's manual for installing an attachment.

WARNING! To Avoid Serious Personal Injury, make sure the pallet fork is securely latched to the attachment mechanism of your unit. Failure to do so could result in separation of the pallet fork from the unit.



DETACHING

On firm level ground, lower the loader arms until the attachment is on the ground. Follow your tractor and loader operator's manual for detaching (removing) an attachment.

OPERATION

1. Approach the load in such a fashion that the weight will be centered between the fork tines. The heaviest side should be closest to the fork frame and not near the tips of the fork tines.
2. Before lifting, make certain the fork tines are completely under the load and level.
3. Lift the load slightly to make sure the load is stable. If the load appears unstable, lower and reposition the tines to achieve full stability.
4. Raise the loader to the MINIMUM height required for the terrain.
5. During material handling: keep the fork tines level, stop and start the loader gradually, slow down before turning and avoid obstacles, bumps or holes.

Check load frequently to ensure stability.

Adjusting The Fork Tines

With the loader arms lowered and completely rolled back, shut down the tractor, set the parking brake and remove the key. (If the tines are still in contact with the ground the loader arms may need to be raised just enough to eliminate contact.)

From the right side of your pallet fork, adjust the position of the right fork tine by turning the knob to the unlock position and sliding the fork tine to the desired location. Turn the knob back to lock the fork tine in place. Make sure that the latch has been set into a notch and therefore securing the tine to the frame.

Move to the left side of the pallet fork frame and repeat the adjustment procedure to the left fork tine. Make sure that the left tine is the same distance from the center of the frame as the right tine.

INSTALLATION AND OPERATION

WARNING! NEVER EXCEED THE RECOMMENDED LIFTING CAPACITY OF ANY APPROVED FORK TINES OR THE LOADER.



NOTE: Fork tine capacities are pounds per pair at a 24" load center. (The center of gravity of the allowable loads must be applied within the first 24" of the fork tines when measured from the front face of the vertical section of the fork tine out toward the tip of the horizontal section of the fork tine.)

Limited Warranty

Except for the Excluded Products as described below, all new products are warranted to be free from defects in material and/or workmanship during the Warranty Period, in accordance with and subject to the terms and conditions of this Limited Warranty.

1. Excluded Products. The following products are excluded from this Limited Warranty:

(a) Any cable, part that engages with the ground (i.e. sprockets), digging chain, bearing, teeth, tamping and/or demolition head, blade cutting edge, pilot bit, auger teeth and broom brush that either constitutes or is part of a product.

(b) Any product, merchandise or component that, in the opinion of Paladin Light Construction¹, has been (i) misused; (ii) modified in any unauthorized manner; (iii) altered; (iv) damaged; (v) involved in an accident; or (vi) repaired using parts not obtained through Paladin Light Construction.

2. Warranty Period. The Limited Warranty is provided only to those defects that occur during the Warranty Period, which is the period that begins on the first to occur of: (i) the date of initial purchase by an end-user, (ii) the date the product is first leased or rented, or (iii) the date that is six (6) months after the date of shipment by Paladin Light Construction as evidenced by the invoiced shipment date (the "Commencement Date") and ends on the date that is twenty-four (24) months after the Commencement Date.

3. Terms and Conditions of Limited Warranty. The following terms and conditions apply to the Limited Warranty hereby provided:

(a) Option to Repair or Replace. Paladin Light Construction shall have the option to repair or replace the product.

(b) Timely Repair and Notice. In order to obtain the Limited Warranty, (i) the product must be repaired within thirty (30) days from the date of failure, and (ii) a claim under the warranty must be submitted to Paladin Light Construction in writing within thirty (30) days from the date of repair.

(c) Return of Defective Part or Product. If requested by Paladin Light Construction, the alleged defective part or product shall be shipped to Paladin Light Construction at its manufacturing facility or other location specified by Paladin Light Construction, with freight PRE-PAID by the claimant, to allow Paladin Light Construction to inspect the part or product.

Claims that fail to comply with any of the above terms and conditions shall be denied.

LIMITATIONS AND EXCLUSIONS.

THIS LIMITED WARRANTY IS IN LIEU OF ALL OTHER WARRANTIES, EXPRESS OR IMPLIED, INCLUDING WITHOUT LIMITATION THE WARRANTIES OF MERCHANTABILITY, FITNESS FOR A PARTICULAR PURPOSE AND ANY WARRANTY BASED ON A COURSE OF DEALING OR USAGE OF TRADE.

IN NO EVENT SHALL PALADIN LIGHT CONSTRUCTION BE LIABLE FOR CONSEQUENTIAL OR SPECIAL DAMAGES.

IN NO EVENT SHALL PALADIN LIGHT CONSTRUCTION BE LIABLE FOR ANY LOSS OR CLAIM IN AN AMOUNT IN EXCESS OF THE PURCHASE PRICE, OR, AT THE OPTION OF PALADIN LIGHT CONSTRUCTION, THE REPAIR OR REPLACEMENT, OF THE PARTICULAR PRODUCT ON WHICH ANY CLAIM OF LOSS OR DAMAGE IS BASED. THIS LIMITATION OF LIABILITY APPLIES IRRESPECTIVE OF WHETHER THE CLAIM IS BASED ON BREACH OF CONTRACT, BREACH OF WARRANTY, NEGLIGENCE OR OTHER CAUSE AND WHETHER THE ALLEGED DEFECT IS DISCOVERABLE OR LATENT.

¹Attachment Technologies Inc., a subsidiary of Paladin Brands Holding, Inc. (PBHI) is referred to herein as Paladin Light Construction.

PALLET FORK ASSEMBLY

36" FORK ASSEMBLY #108307,

42" FORK ASSEMBLY #108308

48" FORK ASSEMBLY #108309

<p>KEEP OTHERS CLEAR.</p>  <p>KEEP LOAD LEVEL.</p> <p>DO NOT LIFT ROUND BALES.</p>	<p>WARNING</p> <p>TO AVOID SERIOUS PERSONAL INJURY OR DEATH</p> <ul style="list-style-type: none">• THIS ATTACHMENT MUST NOT BE USED ON SKID-STEER LOADERS.• DO NOT EXCEED 2300 LBS. LIFTING CAPACITY.• DO NOT EXCEED THE RECOMMENDED LIFTING CAPACITY OF ANY APPROVED FORK TINES.• DO NOT USE FORK TINES FOR PRYING OR ANY PURPOSE OTHER THAN LIFTING. <p>#40966</p>
---	---

BRADCO

U.S. PATENT
NO. 6,881,023
#40880

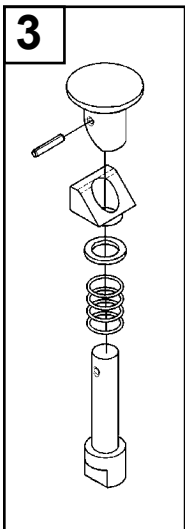
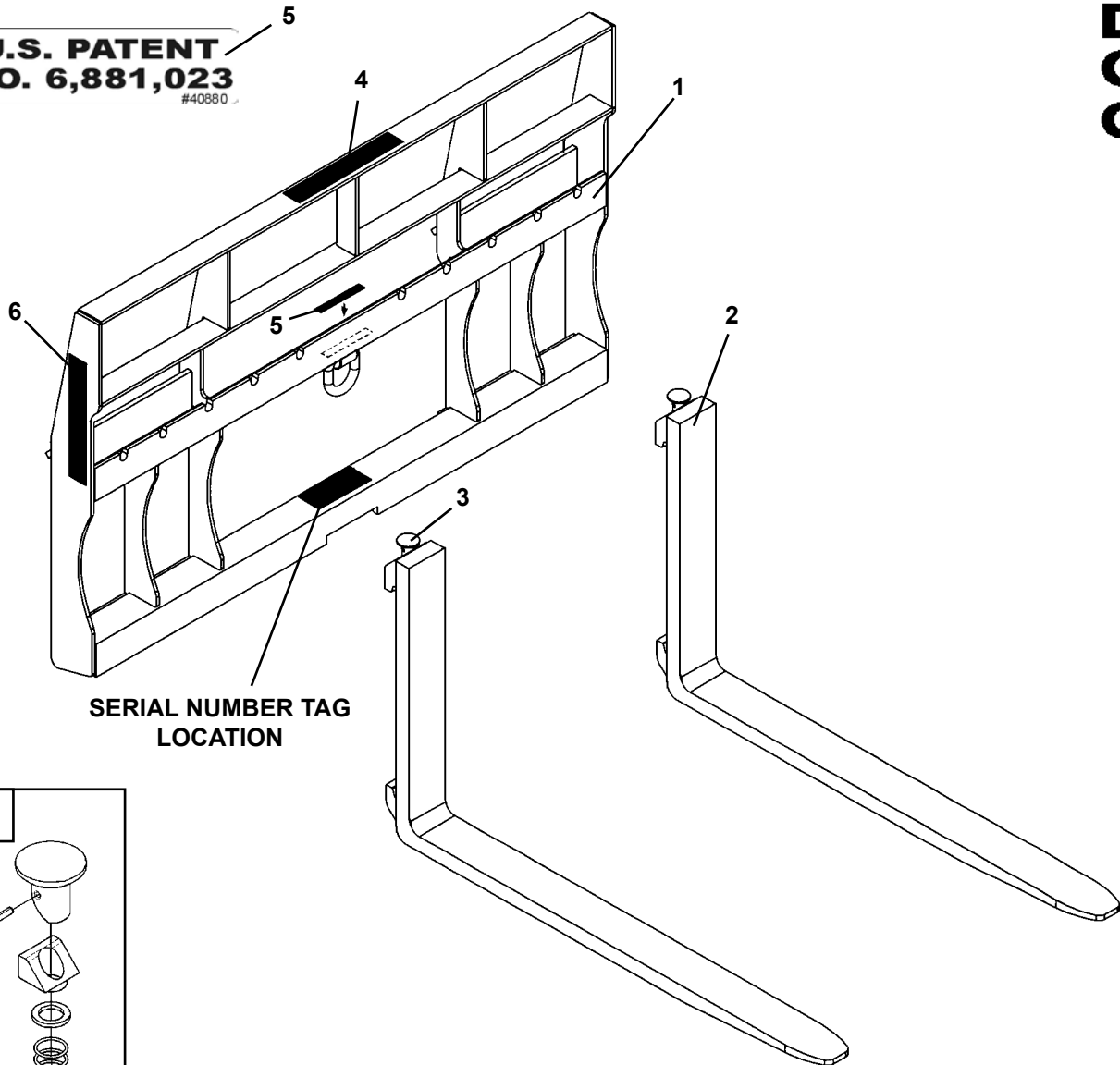

PALLET FORK ASSEMBLY

36" FORK ASSEMBLY #108307,

42" FORK ASSEMBLY #108308

48" FORK ASSEMBLY #108309

<u>ITEM</u>	<u>REQ'D</u>	<u>PART NO.</u>	<u>DESCRIPTION</u>
1	1	107284	Fork Frame
2	1	106218	36" Fork Tines (Pair) (Single Tine #106219)
	1	106220	42" Fork Tines (Pair) (Single Tine #106221)
	1	106222	48" Fork Tines (Pair) (Single Tine #106223)
3	-	102506	Replacement Lock Assembly (Included with Tines)
4	1	40966	Warning Decal, 2300 Lift Capacity
5	1	40880	Patent #6881023 Decal
6	2	40179	Bradco Logo